

8

7

6

5

4

3

2

1

COPYRIGHT INFORMATION

REV.		DESCRIPTION	REVISIONS	DATE	APPROVED

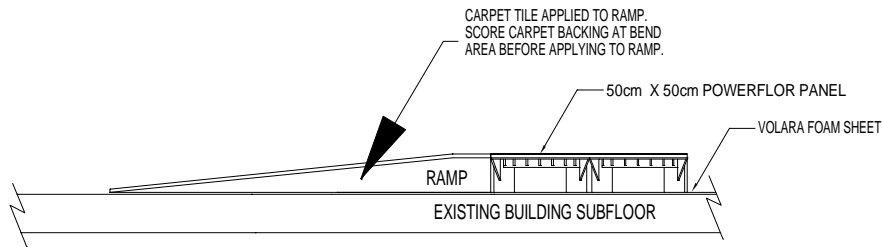
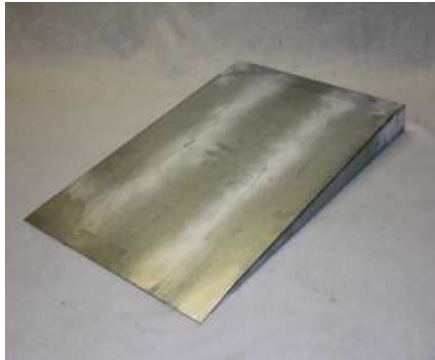

TYPICAL RAMP INSTALLATION

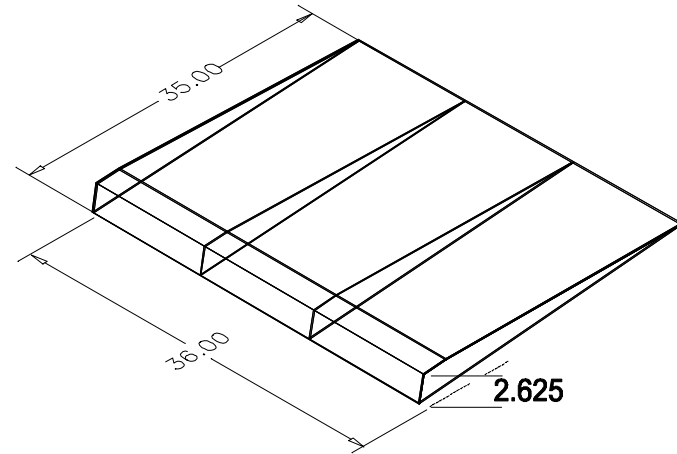

ADA HANDICAP RAMP

- 1. 11 GAUGE STEEL WELDED CONSTRUCTION WITH GUSSETS.
- 2. STANDARD RISE 1:12.
- 3. MEETS ALL ADA REQUIREMENTS.
- 4. WIDTH VARIES TO MEET SITE REQUIREMENTS



CUSTOM PRODUCTS & SERVICES
 6286 Claude Way E, Inver Grove Heights, MN 55076-4435
 PH: 888-444-1202 (Toll Free) or 651-452-0113 Fax: 651-452-2264

E-mail: Info@custom-products.com
 Website: www.custom-products.com

UNLESS OTHERWISE SPECIFIED		PARTS LIST	
DIMENSIONS ARE IN INCHES.		CAG GENERATED DRAWING DO NOT UPDATE MANUALLY	
TOLERANCES ARE:		APPROVALS	DATE
FRACTIONS: DECIMALS ANGLE		J.R. ECKHART	05/13/2016
.XX + .XX		CHECKED	
XXX + .XXX			
MATERIAL		ADA RAMP 1/12 SLOPE	
FINISH		POWERFLOR USA INCORPORATED	
NEXT ASSY		DRAWING NO. 3-123536	
USED ON		SCALE: XXX CAD FILE XXXX.DWG	
APPLICATION		REV. C	
		SHEET XX OF XX	

F

E

D

C

B

A

8

7

6

5

4

3

2

1